

**BONDING AT ITS BEST**  
Mixing systems for metallic powder coatings



**Mixing Technology**

# HIGHEST QUALITY

Producing bonded metallic powder coatings requires highly sensitive processes. First-class, consistently high quality with circulation stability is not obtained by chance, but with Zeppelin's proven technology and perfected process engineering.

## Global leader

Decades of experience were necessary to create the world's most accurate, gentle and reliable system for the bonding process. Our very specific technology combined with product features optimized for bonding ensure absolute process reliability, nearly loss-free production and excellent processing quality of the mixture.

Zeppelin's HENSCHTEL-Mixer®, type process mixer is particularly suitable for the bonding process of glossy metallic powder coatings such as those used in the automotive industry and is now available with optimized design characteristics.

## Optimal features

The process mixer features an elaborate temperature control system with 4 cooling zones: drive shaft, mixing tool, double jacket and bottom shell. The system creates a positive agglomeration of the mix and prevents residues from settling in the vessel and onto the tool. Temperature measuring points at various locations ensure precise compliance with the process while the bearing temperatures of the mixing tool shaft are constantly monitored. Control of residual oxygen content and nitrogen inerting comply with the required explosion protection measures.

The entire bonding process can be controlled extremely precisely and offers certified and absolute process reliability. Your advantages: premium quality, efficient production, constant brilliant powder coatings – short amortization period of your plant.

## Advantages at a glance:

- Trusted technology – global leader
- Guaranteed reproducible quality
- Controlled and absolute process reliability
- No segregation after the process due to complete bonding
- First class brilliance and consistent color quality
- Comprehensive range of accessories
- Explosion protection for safe operation

Microscopic view  
Metallic powder coating

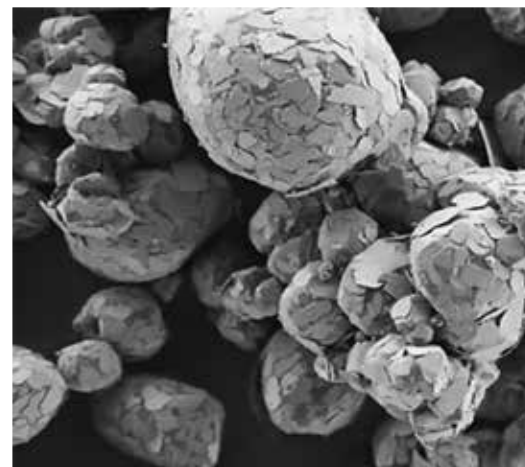

# Step by step to perfect quality

## Process step 1

Plain powder coating is poured into the mixer. In order to dose the precise amount of nitrogen, the oxygen content is continuously monitored (redundant sensors optional) and the nitrogen inerting is adjusted.

## Process step 2

Friction induced energy input heats the mixture until the ideal Tg (softening point temperature / glass transition temperature) of the resin is reached. The effect pigments can now be added.

## Process step 3

The temperature will be kept constant for a defined period until the pigment powder is bonded to the resin.

## Process step 4

The mixture is then cooled gently to avoid excessive agglomerates from building up. Cooling can take place in the process mixer (at intensive cooling) as well as in a downstream cooling mixer, which also enables filling degrees of up to 85%. This process ensures excellent product quality with optimal processing properties.

## Powder coating

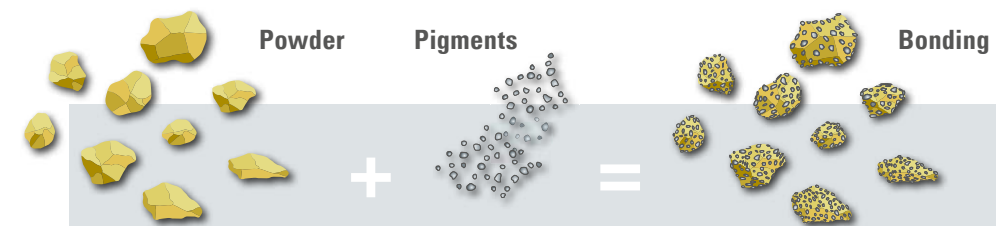

Know how: Highest processing quality, maximum pigment protection, prevention of agglomerations

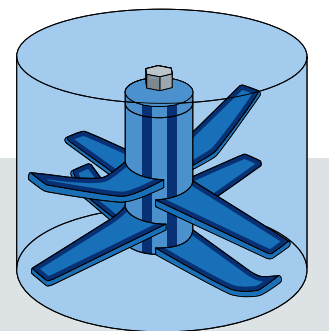

A total of 4 cooling zones ensure reliable stability of the desired temperature

## Better mixing with know-how

The design characteristics of the process mixer have been further enhanced for the specific requirements of effect powder coatings. A very demanding process is required to obtain a premium quality mixture. In the bonding process, the softening point temperature of the resin – to which the effect pigment adheres – is key. The temperature slot at which the texture of this substrate goes from powder to a doughy mass is very narrow. If it has not been reached, the downstream production cycle will be unstable.

## Unique cooling concept

Heat is generated by friction during the intensive mixing. These temperature fluctuations are regulated by the individual cooling zones in the mixer. Each cooled module can be regulated and cooled separately. No other mixer comes as close to glass transition temperature as Zeppelin's HENSCHTEL-Mixer®. The result is first-class processing quality of these valuable powder coatings.

## Technical data

Type	Charge
Laboratory mixer	
MB 10	1.6 – 3.5 kg
Production mixer combination	
MB 75 / KM 150	25 kg
MB 200 / KM 350	75 kg
MB 350 / KM 1050	130 kg
MB 500 / KM 1750	180 kg
MB 600 / KM 1750	220 kg
MB 800 / KM 2200	280 kg
MB 1000 / KM 2200	400 kg
Throughput: 4 batches/hr. at combined operation 2 batches/hr. with process mixer at intensive cooling	



**Pigment hopper**

The feed hoppers are ideal for the bonding application: they are designed according to the amount and pourability of the pigments to be added, offer very good residual discharge, are easy to clean and can be handled safely during transport



**Process mixer**



**Pneumatic hinged lid with deflector**

Hinged design for easier cleaning

**Residual oxygen meter**

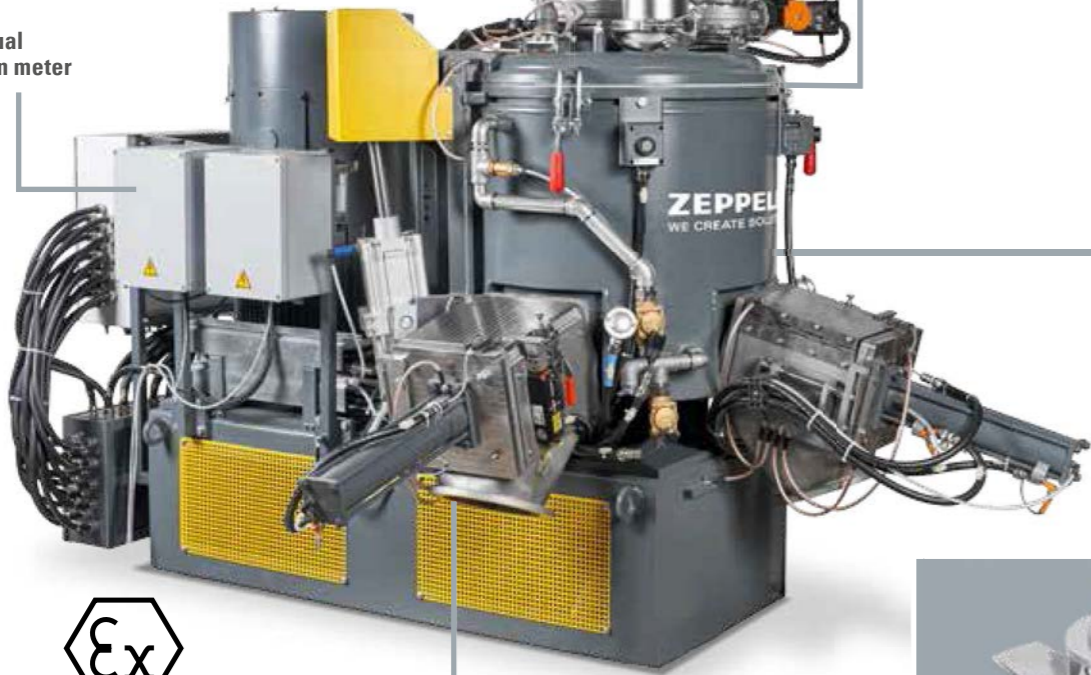

**Discharge with cleaning kit**

Swivel design discharge cylinder and hinged cover plate for easier cleaning



**Mixing tool**

Special self-cleaning one-piece mixing tool with water cooling through the drive shaft right to the tips of the tool blades

**Cooler mixer**



**Hinged lid**

Electrically operated to open at 2/3 of the lid for fastest cleaning when changing recipes while maintaining connection to the process mixer



**Mixing tool**

Special mixing tool for particularly gentle cooling of the mixture



**Discharge with cleaning kit**

Swivel design discharge cylinder and hinged cover plate for easier cleaning

**Combination of process mixer and cooler mixer**

# ZEPPELIN®

WE CREATE SOLUTIONS



## Laboratory mixer

Perfect bonding quality in laboratory scale for your color development and production upscaling

## Presented by:

Zeppelin Systems GmbH  
Mixing Technology  
Henschelplatz 1  
34127 Kassel  
Germany

Tel.: +49 561 801 - 7070  
Fax: +49 561 801 - 5930

[henschel@zeppelin.com](mailto:henschel@zeppelin.com)  
[www.zeppelin.com](http://www.zeppelin.com)

For the complete Zeppelin Systems range please visit our website at  
[www.zeppelin-systems.com](http://www.zeppelin-systems.com)

## Global presence

- Australia
- Belgium
- Brazil
- China
- France
- Germany
- India
- Italy
- Korea
- Russia
- Saudi Arabia
- Singapore
- United Kingdom
- USA